

Jacking system for self-elevating unit

—

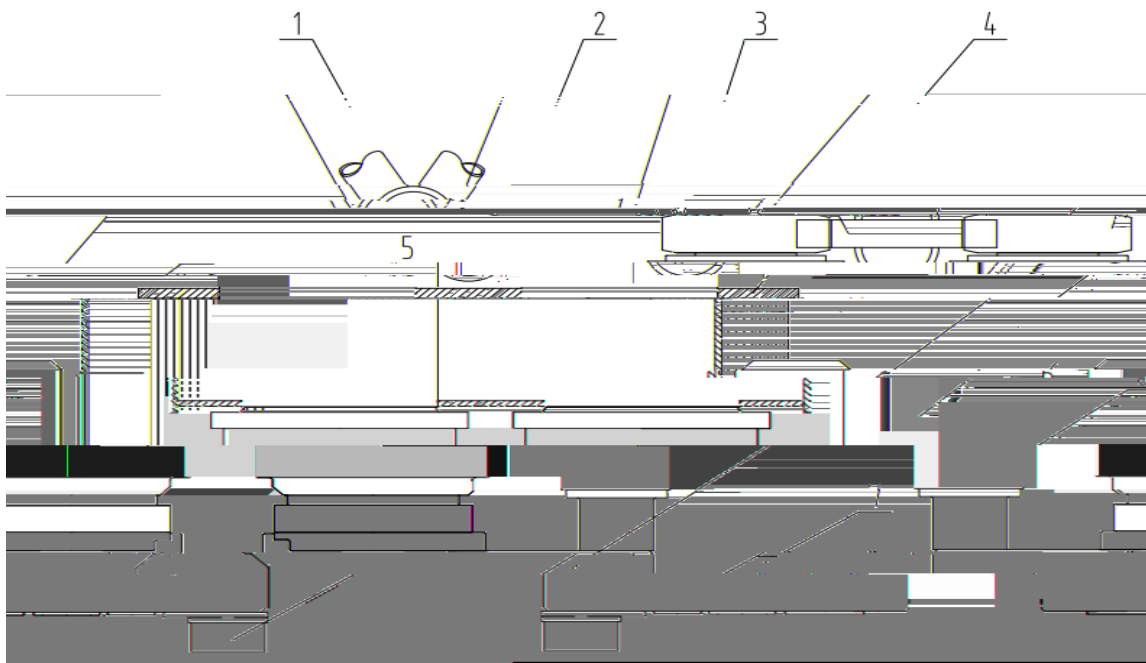

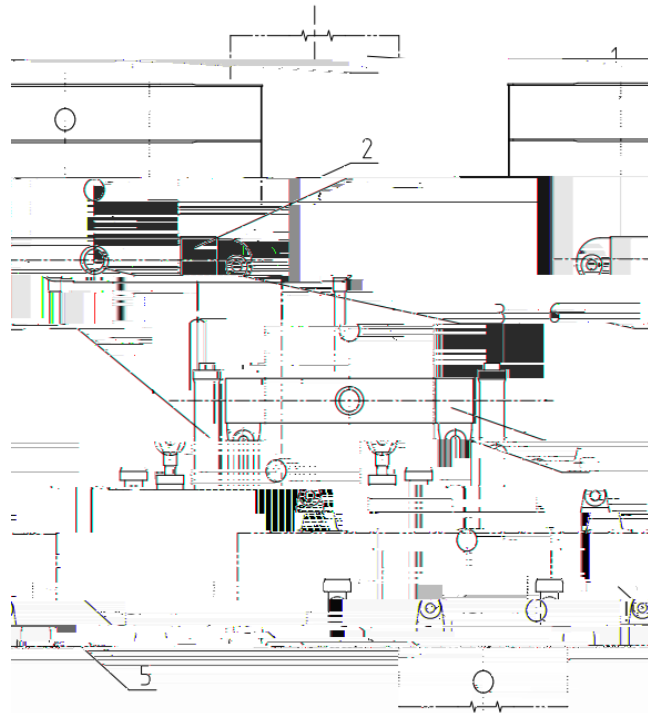

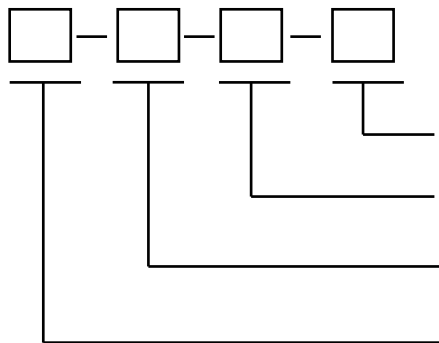

—



—
